

Ciff furniture

THE CHINA INTERNATIONAL FURNITURE FAIR MAGAZINE

Shanghai 11-14
September 2017

The Business of Furniture | SPECIAL EDITION

BoF

*BETTER LIFE
BETTER WORK*

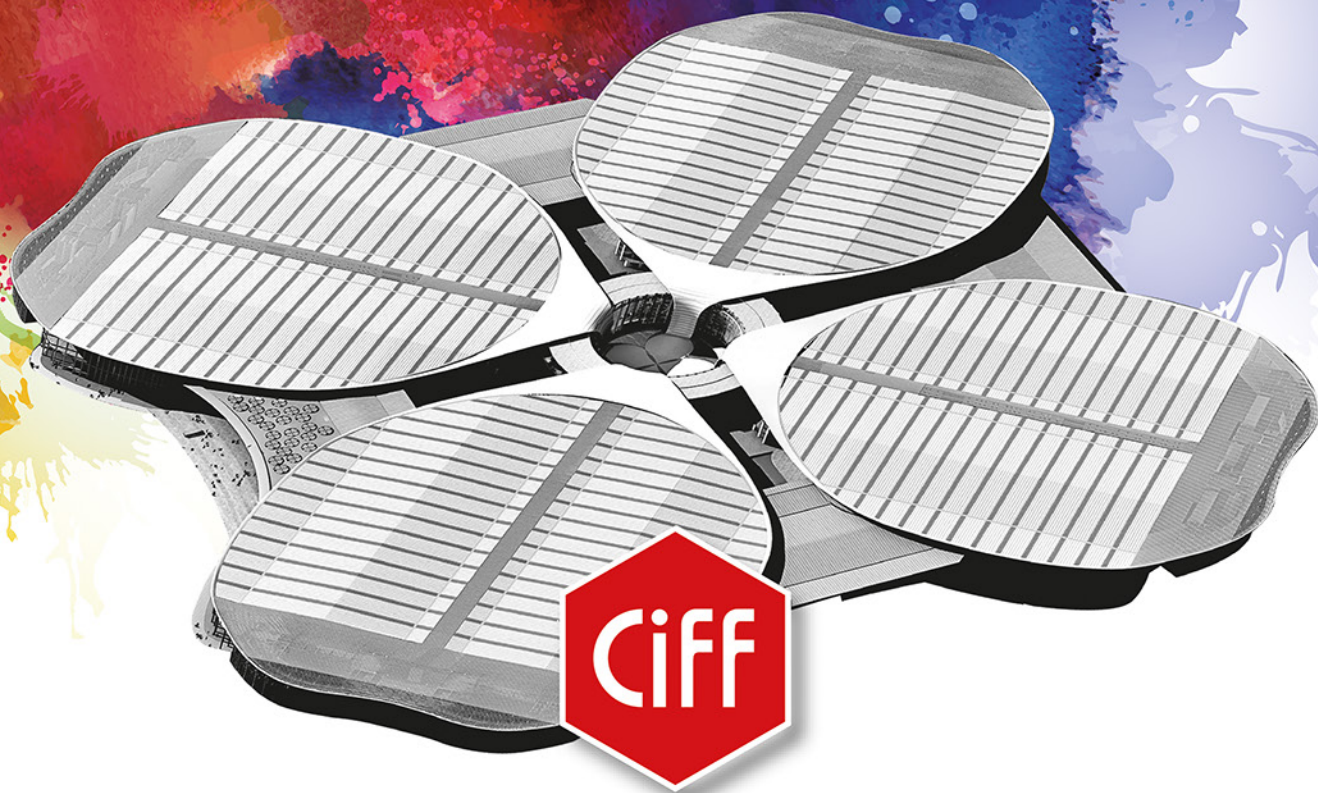

Welcome



2,000
Exhibitors



400,000
sqm



90,000
Attendees

The 40th edition of CIFF, the world's largest furniture exhibition, and the most important business platform in Asia, will be held in **Shanghai Hongqiao**, showcasing leading brands of home furniture, home decor, home textiles, outdoor furniture, office furniture, furniture machinery & raw materials.

CIFF has meticulously planned a furniture event for "**Better Life, Better Work**", hosting **2,000 brands** and **90,000 professional visitors**, with the aim clearly set on enhancing the quality of the exhibition and providing excellent service and exceptional furniture. Products perfect for all lifestyles, even for the most demanding markets.

The **400,000 square-meter exhibition** covers the themes of the entire industry chain under the concept of Whole Home Decor, and integrates them so as to display their individual features. Whatever the position of their stand, exhibitors can catch the attention of their clients and meet with them, while visitors can also find their way easily around the halls.

The constant aim of CIFF-Shanghai is to achieve this seemingly impossible objective.

The five major industry themes aim to satisfy the needs of exhibitors and visitors by means of careful adjustments and a systematic layout. The recolored "Four-leaf Clover" of the National Exhibition & Convention Center (Shanghai) in Hongqiao seems brighter and fresher.

ciff.furniture is a publication by
China Foreign Trade Guangzhou Exhibition General Corp.

publishing concept and coordination by
Edimotion

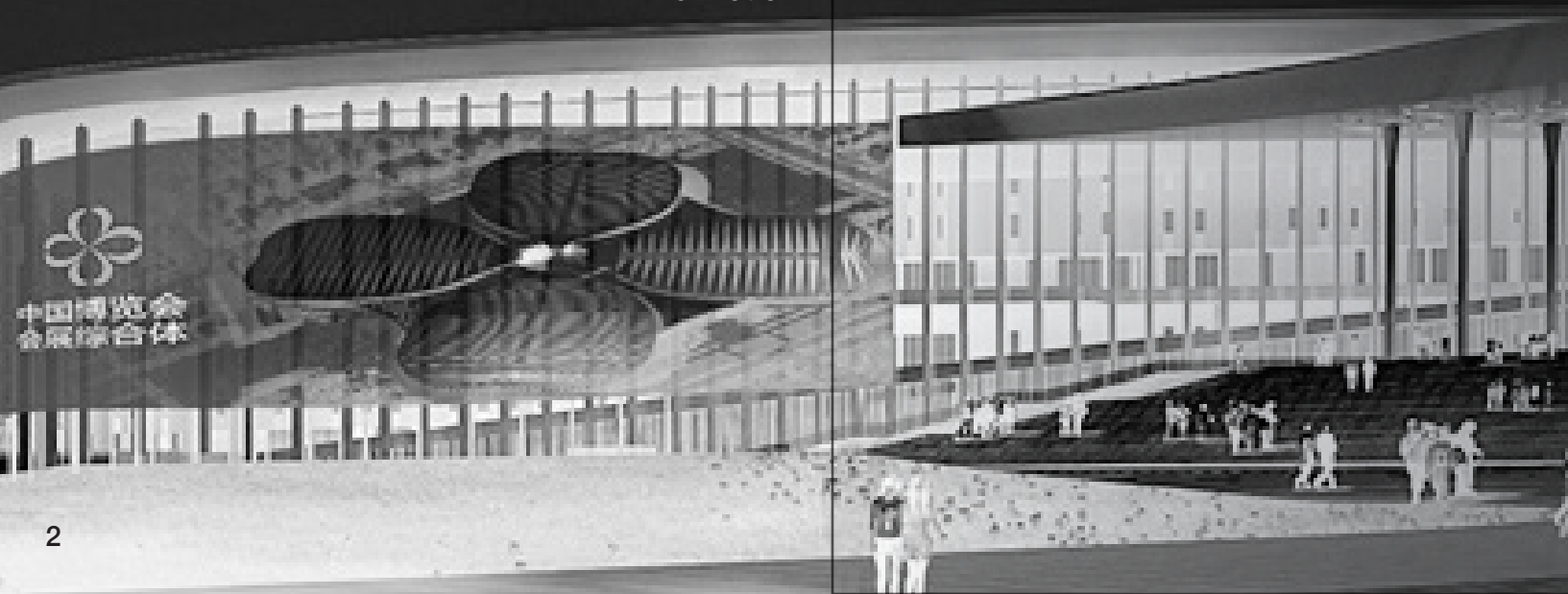

Index

- 4
Welcome
- 5
Facts & Figures
- 6
How to find NECC
- 7
Entry Guide
- 8
Hall Plan
- 9
Modern Home Furniture
- 16
Homedecor & Hometextile
- 22
Office Furniture
- 24
Outdoor & Leisure
- 30
Furniture Machinery &
Furniture Raw Materials
- 36
Tasting Zen in Tea
- 40
You May Not Believe It...
- 43
Shanghai, the city where
everything is possible!

www.ciff.furniture



Welcome

I warmly invite you to visit the next edition of CIFF in Shanghai, a dynamic platform to create market value for the furniture sector, industry and enterprises, striving for a better future for exhibitors and visitors.

CIFF takes place twice a year in **Guangzhou in March** and in **Shanghai in September** focusing on both the international market and the broader Chinese one.

China presents more positive factors and opportunities than challenges. In the next 4 years, China will build a moderately prosperous society in all respects.

China will stand out in the global market in the 21st Century.

CIFF helps the enterprises occupy the commanding heights of China market based on the strategic layout in the Pearl River Delta and the Yangtze River Delta, the two most dynamic commercial centers in China, thanks to their powerful engines and great influence.

We always believe that exhibitors and visitors are the true masters of the exhibition. The central idea of CIFF is "All-around Matching" based on the entire industry chain of furniture and home furnishings to achieve **brand matching, trade matching, fashion matching, design matching, decor matching, technology matching, material matching and media matching.**

In 2017 CIFF brings together nearly 6,000 exhibitors and host more than 250,000 professional visitors from over 200 countries and regions, covering the themes of home furniture, home décor & home textile, outdoor & leisure furniture, office furniture, commercial furniture, hotel furniture and furniture machinery & raw materials.

The 1,15 million-square-meter CIFF will create more value for enterprises by all-round matching.

Different from the general business organizations, **we are a state-owned organizer in the exhibition industry. We serve exhibitors and visitors** wholeheartedly dedicatedly centering on the market demands, instead of pursuing private interests.

We believe that we can realize the China Dream of better life for all the people in the furniture and exhibition industries as long as we organize the exhibitions dedicatedly and stand together with the sector, industry and enterprises!



Li Deying
general manager
China Foreign Trade Exhibition General Corp.

A stylized handwritten signature in black ink, appearing to read '李德迎'.

Facts & Figures

Date of the event	11-14 September 2017
Organizer	China Foreign Trade Exhibition General Corp.
Frequency	Twice a year (March in Guangzhou, September in Shanghai)
Venue	National Exhibition & Convention Centre (Shanghai • Hongqiao)
Sectors	Home Furniture, Homedécor & Hometextile, Outdoor & Leisure, Office Furniture, Machinery & Materials
Opening times	daily from 09:00 a.m. to 06:00 p.m.
Visitors Target	Every type of furniture and furnishing specialist trade, specialist bed retailers, interior designers, architects, designers, planners, joiners, carpenters, interior decorators
Website	www.ciff.furniture
Contact	Ms. Gina Ho ginaho@fairwindow.com.cn Ms. Victoria Cao caoxw@fairwindow.com.cn Mr. Joseph Chan chenxian@fairwindow.com.cn



How to find NECC

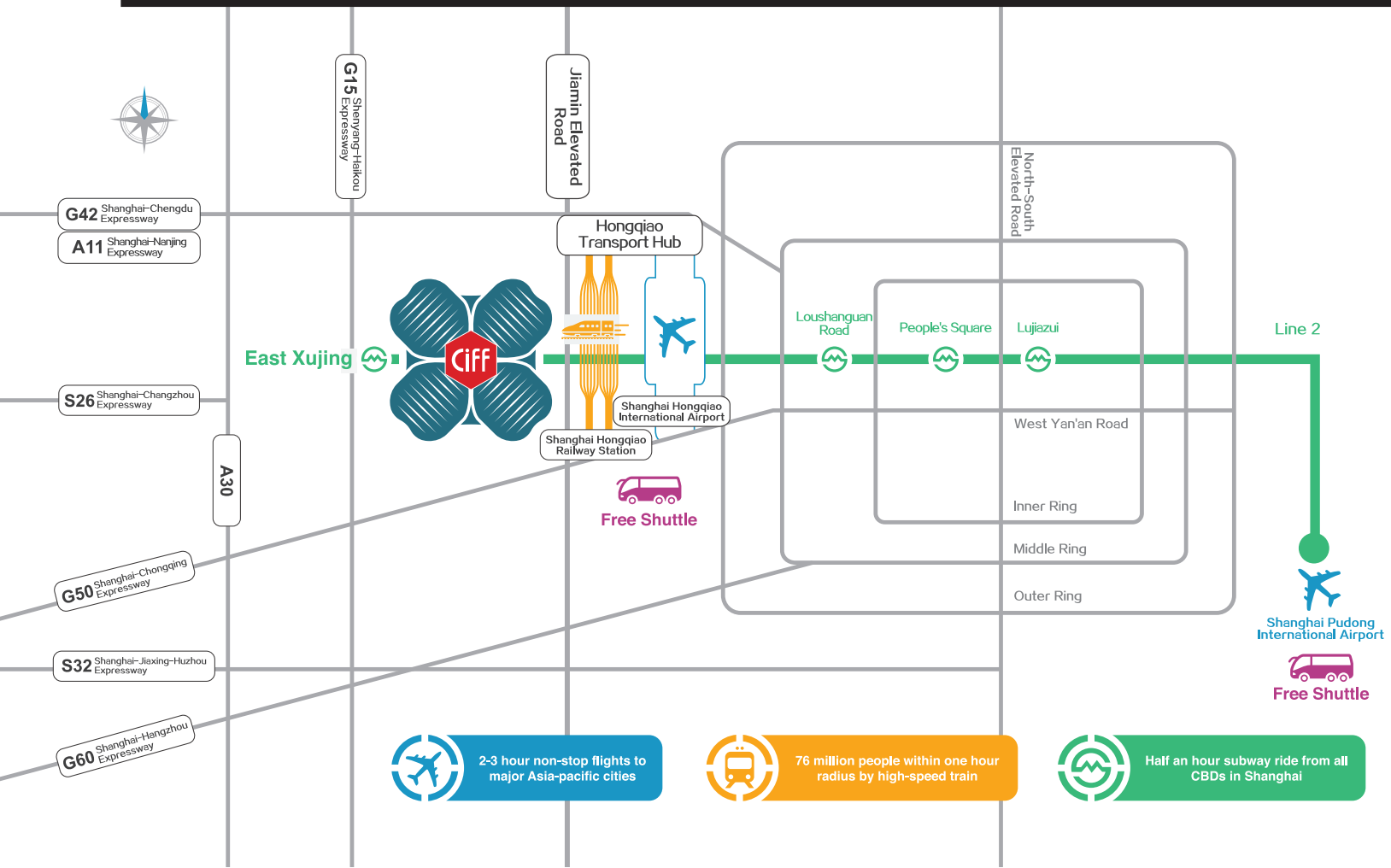

Airline



Hongqiao Airport: Take Metro Line 2
Pudong Airport: Take Metro Line 2

Railway



Hongqiao Railway Station:
Take Metro Line 2

Metro



Metro Line 2, East Xujing Station

Free Shuttle Bus



Hongqiao Airport→NECC
Pudong Airport→NECC
Hongqiao Railway Station→NECC

Taxi



Please show the following Chinese to the driver:





Entry Guide

1. Pre-registration

Pre-register on CIFF
official website



Receive electronic
confirmation letter
with QR Code



Print confirmation
letter or bring the
QR Code



Direct admission

Pre-register on WeChat

- With the printed confirmation letter or electronic QR Code, visitors can have direct access into the venue.
- By showing the confirmation letter, Visitors can obtain a **free electronic show catalogue** and enjoy **free tea-break** service in the VIP room.

2. On-Site Registration

Invitation Letter+ Business Card
or Passport + Business Card



Register for free



Admission





匠心质造
全能对接
Better Life
Better Work

The 40th China International Furniture Fair (Shanghai)

Home Furniture

- Classic Hall 1
- Customized and Smart Home Hall North Hall
- Modern Furniture Brands Hall 3, 4.1
- Sofa Premium\Sleep Center 4.1
- Sofa Brands Hall 6.1
- Design Hall Hall 2
- International Hall 5.1

Commercial Office & Hotel Furniture

- Fashion Office 7.2
- Fashion Office 8.2

Homedecor

- Home Decoration & Home Textiles 5.2

Outdoor & Leisure

- Outdoor & Leisure 6.2

Furniture Machinery & Furniture Raw Materials

- Raw Materials / Components / Machinery Miscellaneous Hall 7.1
- Furniture Machinery 8.1

- Forums & Events 4.2

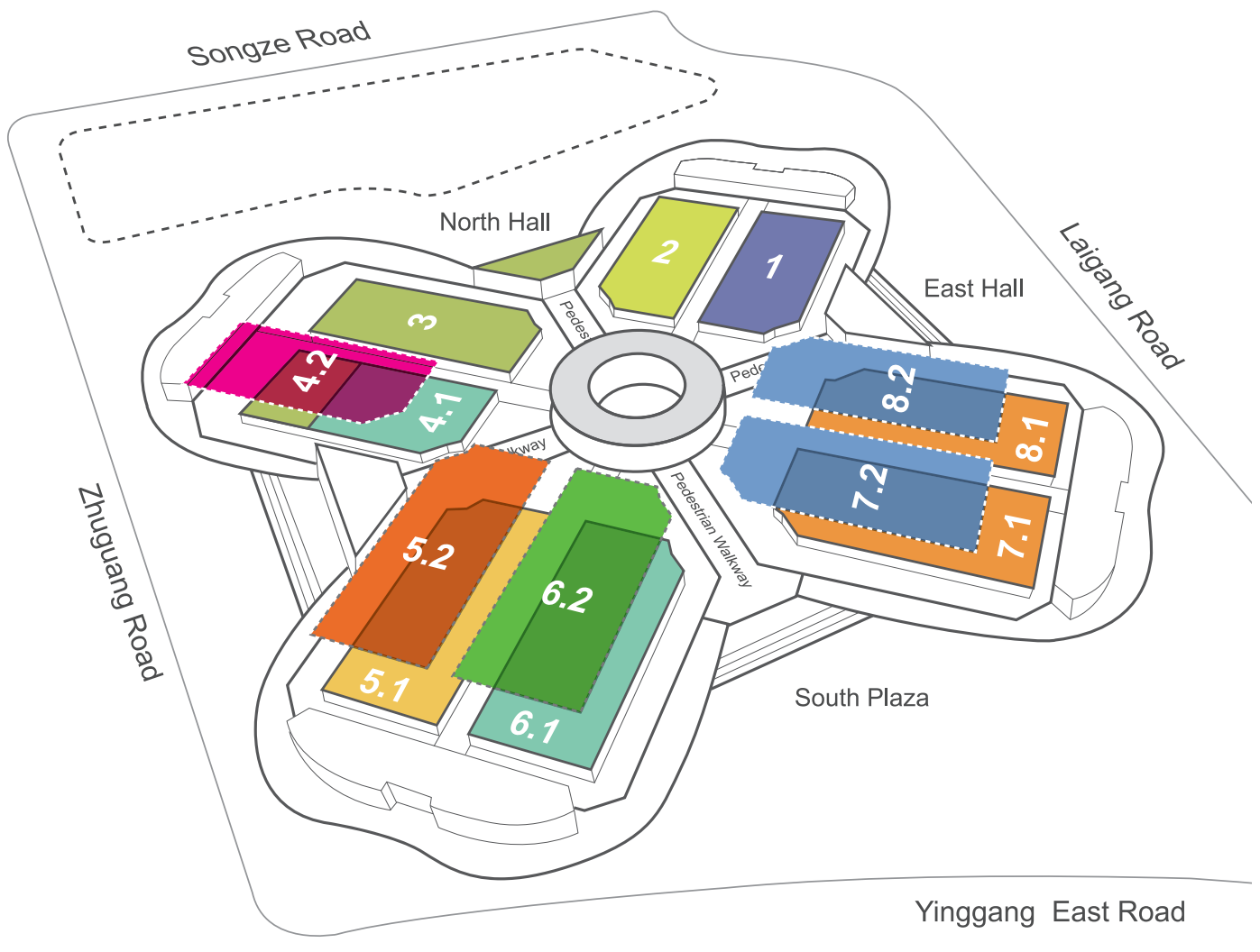



Modern Home Furniture

The Home Furniture sector is located on the first floor of the venue so as to greatly enhance the integrity of the themes. Whether they walk clockwise or counter clockwise, and without crossing the hall, visitors can easily find premium home furniture and experience the industry trends.

This sector will take up 7 halls: **Hall 1, Hall 2, North Hall, Hall 3, Hall 4.1, Hall 5.1 and Hall 6.1**. Each one will propose a distinctive theme and have a specific positioning.

The **North Hall** will be used for the Customized Furniture/Smart Home area, **Hall 1** will showcase European & American Lifestyle and **The Design Hall will be located in Hall 2**. Modern Furniture Brands will be located in **Halls 3 and 4.1** and The Sofa Premium & Sleep Center will be located in **Hall 4.1**, while **The International Hall has been moved to Hall 5.1** and Sofa Brands will be located in **Hall 6.1**. This clustered layout will enable visitors to locate their target products quickly and will further enhance procurement efficiency and quality.

Modern Furniture:

Living Room Furniture, Bedroom Furniture, Soft Furniture, Sofa, Dining Room Furniture, Children Furniture, Teenage Furniture

Classical Furniture:

European Style Furniture, American Style Furniture, Neo-classical Furniture, Classical Soft Furniture, Chinese Mahogany Furniture

1-2-3-4 Sepsion



Products preview



- 1 Zhongge
- 2 Great & Life
- 3 Huahe Furniture
- 4 Huahe Furniture





5
St Moya
6
St Moya
7
Tangtai



Products preview

- 1
- Gold King
- 2
- Gold King
- 3
- Gomlden
- 4
- Gomlden





- 5
- Debel
- 6
- Singbee
- 7
- Hulubao
- 8
- Hulubao



Products preview

- 1 Home Paint
- 2 Home Paint
- 3 Lebetter



2



1



3



4



4
Ouevane
5
Ouevane
6
Lebetter
7
Lebetter

5

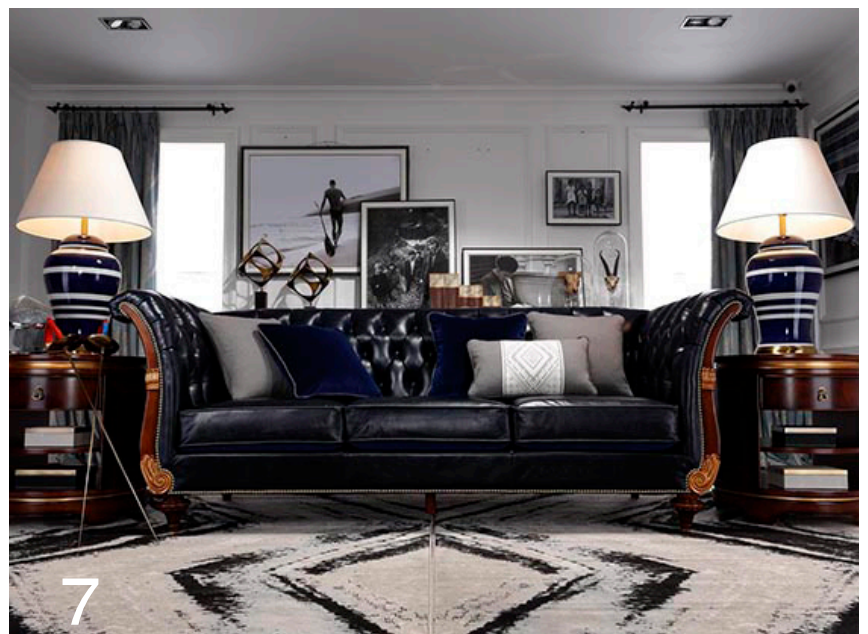

Homedecor & Hometextile

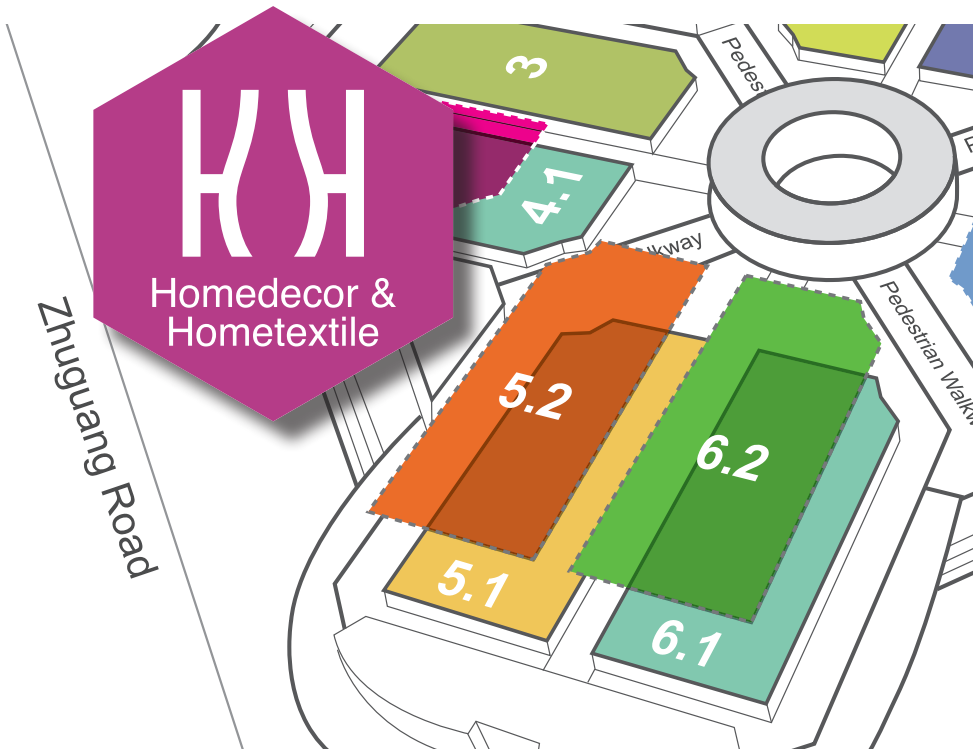

Homedecor

Home Decoration & Home Textiles 5.2

The **Homedecor & Hometextile** sector has been **relocated to Halls 5.2**, just besides the **Outdoor & Leisure** sector: **these two sectors are highly specialized and closely linked**. In order to facilitate procurement, the artificial flowers and gardening decoration in the Home décor sector complement

the garden furniture and courtyard tables & chairs in the Outdoor & Leisure sector. Both sectors are only one step from the International Hall (Hall 5.1) and Sofa Brands (Hall 6.1). **A high degree of integration of Whole Home Decor elements** will certainly spark unexpected ideas.

Homedecor & Textile:

Carpets & Rugs, Artificial Flowers, Picture, Mirrors & Frames, Pottery & Glassware, Resin, Plastic & Metal Crafts, Lighting, Phone, Clock, Carvings, Small Furniture





-
- 1 Yipinchanxin
 - 2 Yipinchanxin
 - 3 Globak Views
 - 4 Globak Views
 - 5 Yanliao Kuai
 - 6 Vasini Rugs



Products preview

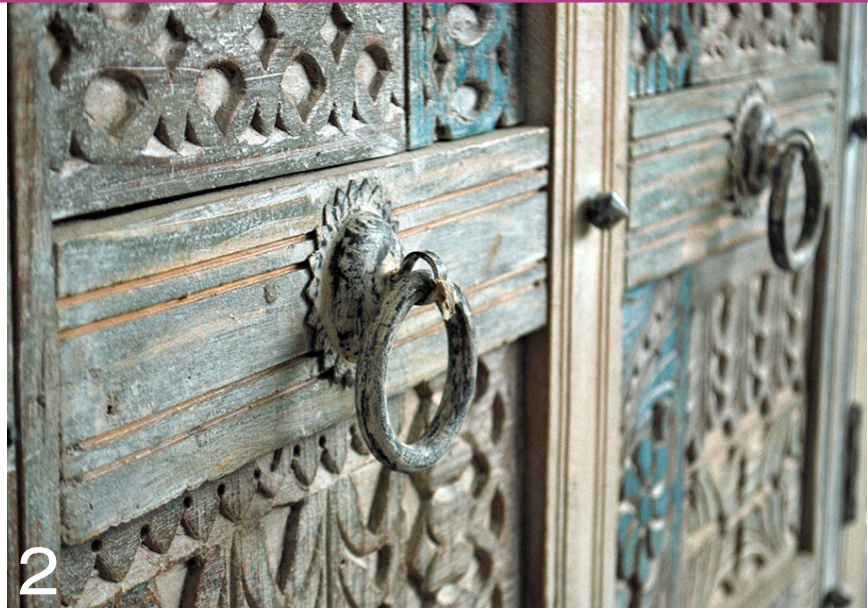

-
- 1
Silk Music
 - 2
Silk Music
 - 3
AEW
 - 4
Silk Music



5

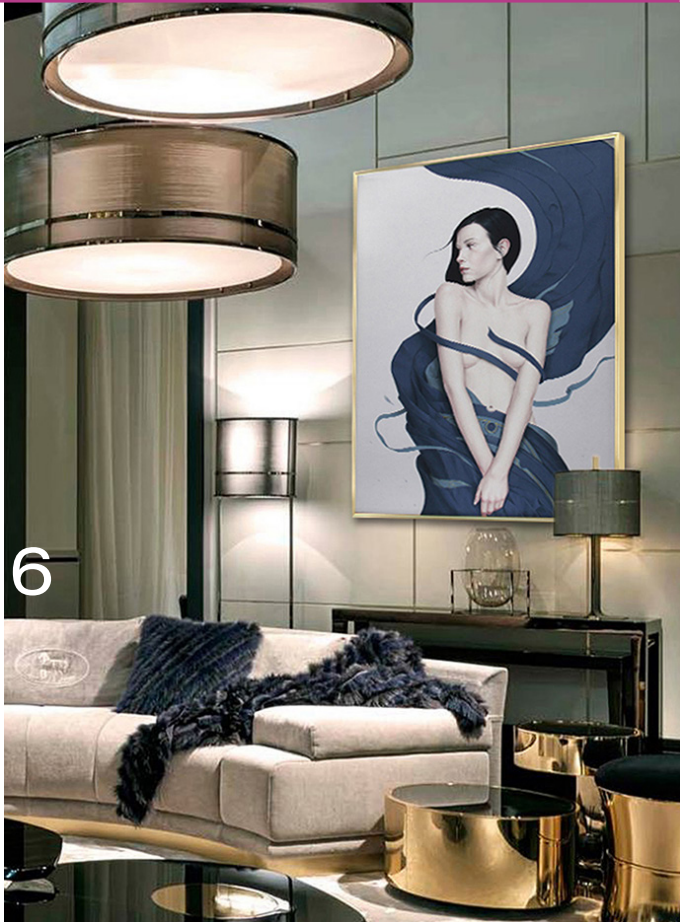

6



7



8

- 5 Uttermost
- 6 Vati International
- 7 Silian
- 8 Vati International

Products preview

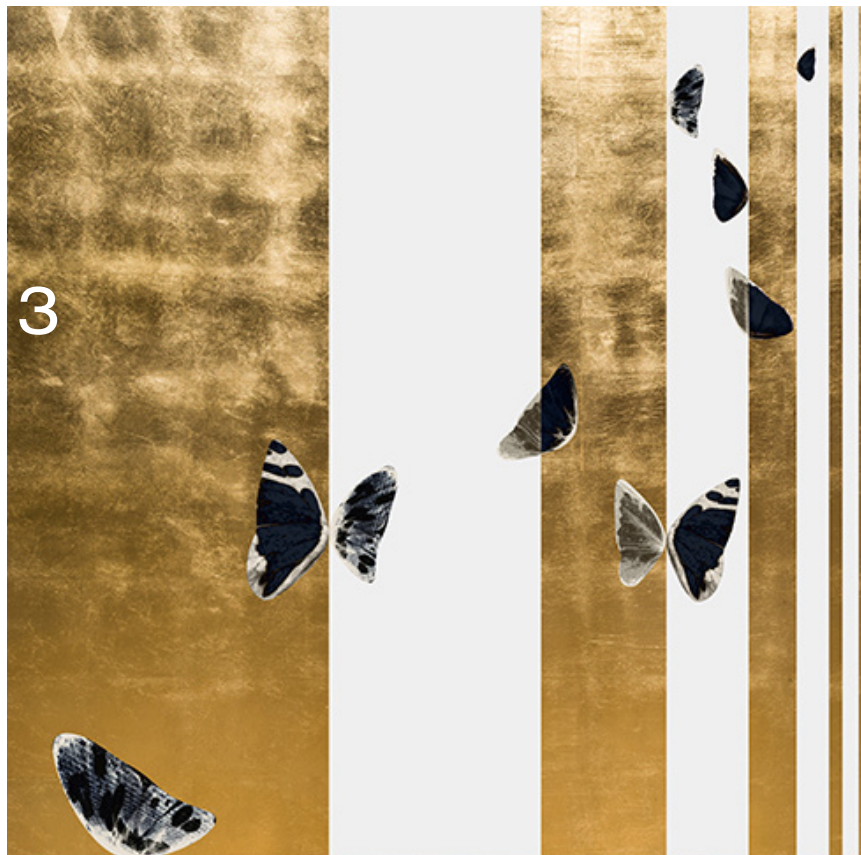
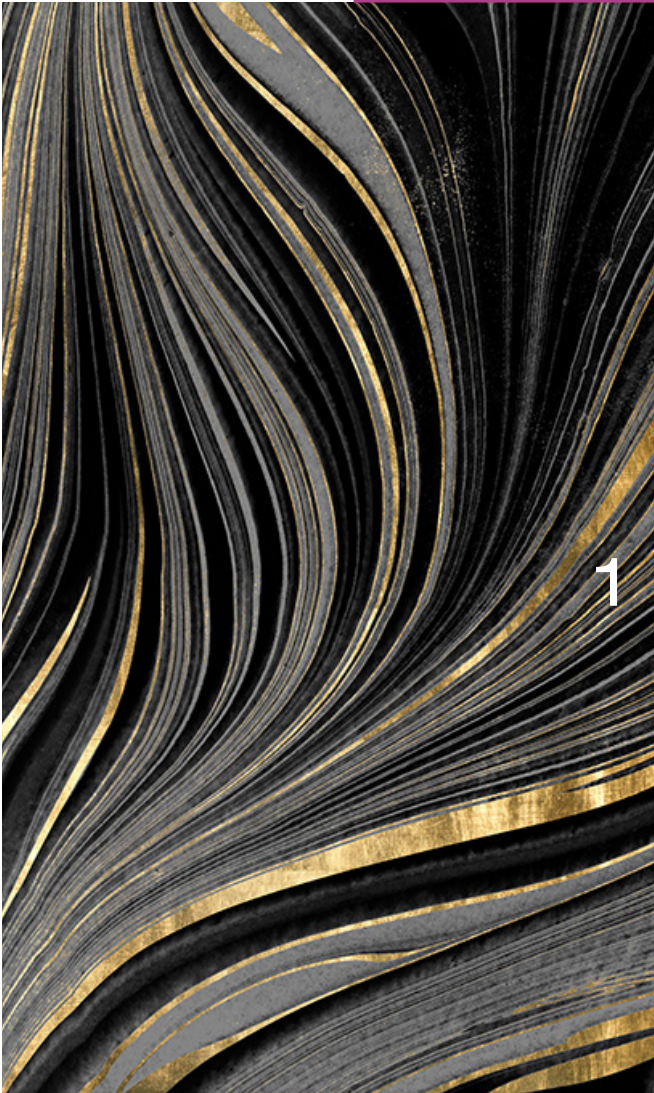

-
- 1
The Color Wheel Gallery
 - 2
Tikanna
 - 3
The Color Wheel Gallery

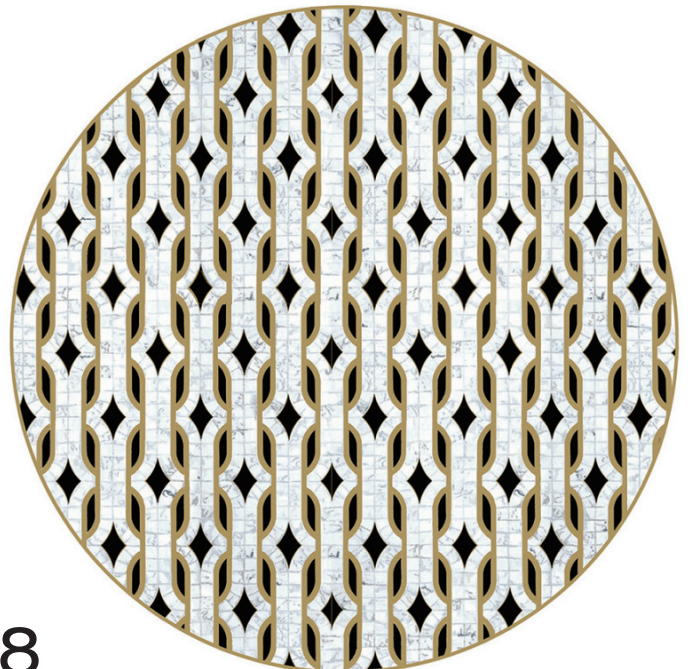

4
Uttermost
5
Tikanna

6
Yalong
7
Yalong

8

Office Furniture

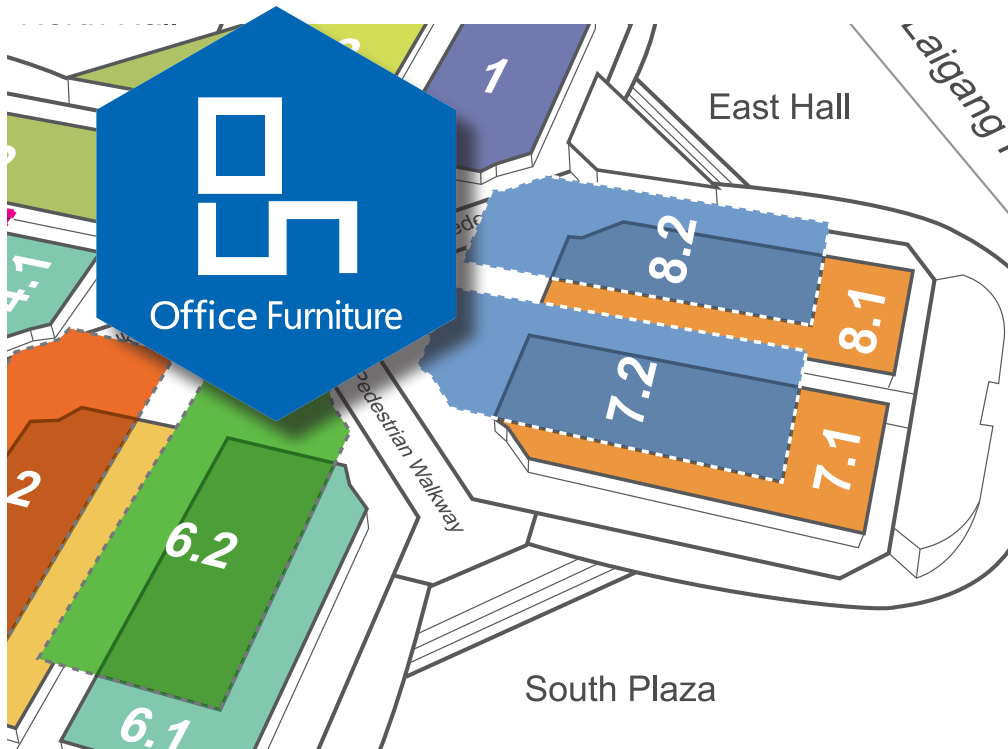

Commercial Office & Hotel Furniture

Fashion Office	7.2
Fashion Office	8.2

The Office Show will have Halls 7.2 and 8.2 and bring together the excellent businesses operating in the office and hotel furniture industry, making **the layout of the specialized themes more simple and coherent, while also enhancing the impact.**

In addition to the **U-shaped** layout with **three**

aisles running throughout the entire venue and the second half of the exhibition area, the 40th CIFF-Shanghai will **optimize exhibition circulation and introduce innovative kinked aisles allowing clear views of the booth facades** and offering 360-degree views of the venue, thus further enhancing the exhibition experience.

Office Furniture:

Office Furniture: Office Seating, Book Shelves, Office Desk/Table, Safe Cabinet, Partition, Storage Unit, Partitioning Wall, Filing Cabinets, Office Accessories

Hotel Furniture: Hotel Furniture, Mattress, Restaurant Furniture, Sofa, Bar Chair & Desk

Commercial Furniture: Public Furniture (Airport Furniture, Theatre/Auditoria Furniture and so on), Public Seating, School Furniture, Laboratory Furniture





-
- 1
 - Rait
 - 2
 - Liangsheng
 - 3
 - Liangsheng



Outdoor & Leisure

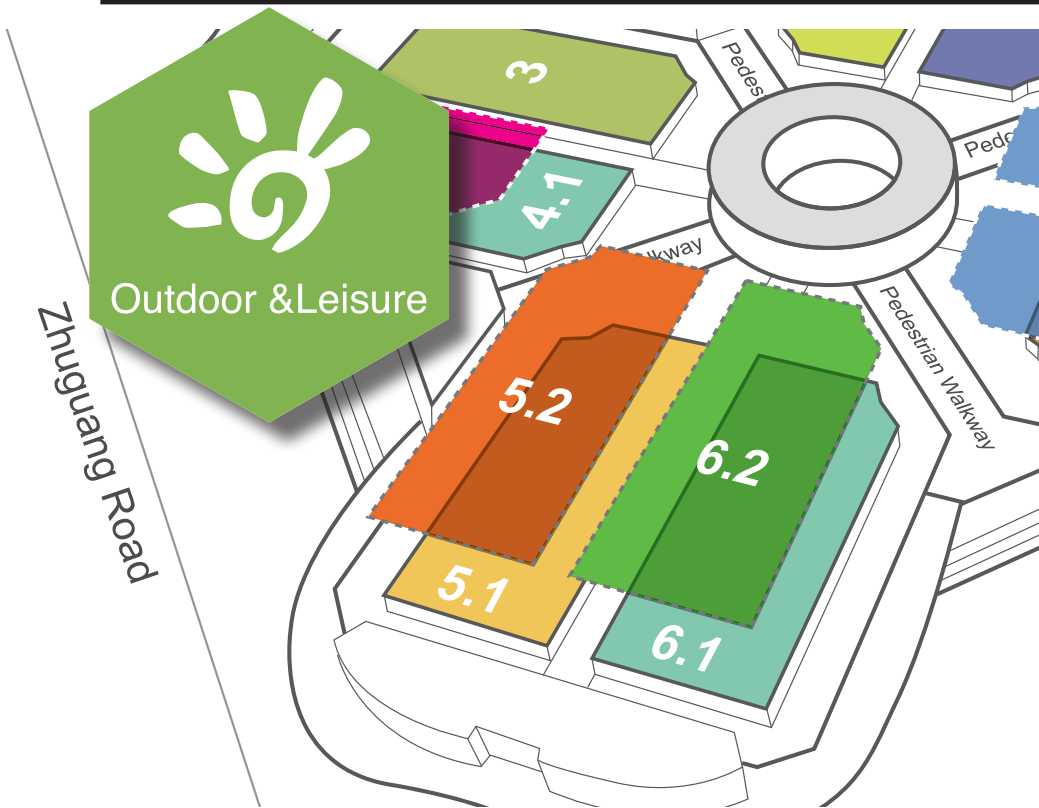

Outdoor & Leisure

Outdoor & Leisure 6.2

The **Outdoor & Leisure** sector, with the theme of “**Bringing Nature Home**”, will ally nearly 150 powerful enterprises covering whole industry chains of outdoor furniture to present a unique outdoor furniture leisure show of about 30,000 square meters, providing one-stop solution to leisure space for family residential

and commercial places (tourism real estate, hotels, resorts, clubs, etc.). As one of the few independent outdoor furniture shows in China, the **Outdoor & Leisure** will be the **first choice platform for top brands** in home and abroad as always. The participating brands in this Fair are more extensive than before.

Outdoor & Leisure:

Outdoor Living: Garden Furniture, Leisure Tables & Chairs, Sun-shading Equipment Outdoor Items
Outdoor Activities: Barbecue Items, Outdoor Tents, Garden Decorations, Tool and Equipment



1



2



3

- 1 Maryard
- 2 Tunqi
- 3 Maryard
- 4 Maryard
- 5 Tunqi



4



5

Products preview



- 1
Spring Sun
- 2
Wapus
- 3
Spring Sun
- 4
Wapus





5



6

- 5 Qinda Umbrella
- 6 Fanyu
- 7 Higold
- 8 Higold



7



8

Products preview



1



2

- 1
Royal Rich
- 2
Sonne
- 3
Varmax
- 3
Spring Sun
- 4
Sonne
- 5
Royal Rich



3



4



5



- 6
- DivanoLounge
- 7
- DivanoLounge
- 8
- MX
- 9
- MX



Furniture Machinery & Furniture Raw Materials

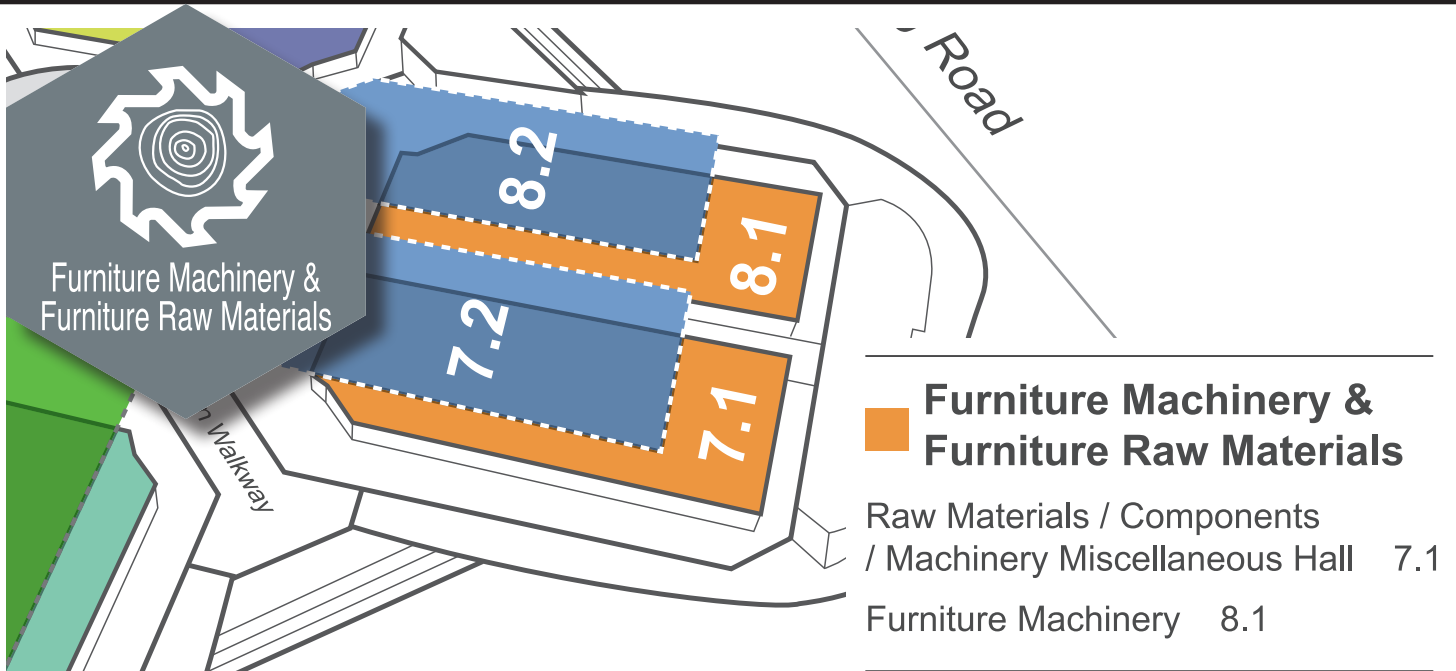

The Furniture Machinery & Furniture Raw Materials sector has been systematically modified and will use Halls 7.1 and 8.1 to display the most complete range of materials and accessories (Hall 7.1) and the most sophisticated furniture machinery (Hall 8.1), next to the furniture brands, in order to strengthen the advantages of the entire industry chain.

From the 2018 edition of CIFF-Shanghai onward,

Machinery & Materials:

Machinery: Edge banding machine, Wood processing, Drying equipment, Engraving machine, Leather tailoring machine, Tools & cutters, Pneumatic tools, Machines for upholstery & bedding
Furniture Materials: Hardware fitting, Semi-finished products for office furniture, Aluminium section for modular furniture, Panels & Stone, Upholstery & Bedding, Packing materials, PVC & Veneers, Fabrics & Leather, Chemical materials

China (Shanghai) International Furniture Machinery & Woodworking Machinery Fair will be jointly organized by China Foreign Trade Guangzhou Exhibition General Corp. and Adsale Exhibition Services Ltd. This new strategic cooperation aims at providing the industry with an international and resourceful exhibition where both exhibitors and buyers can explore their business opportunities in this professional platform.





2

3



4

- 1 Luyulan Decor
- 2 Xiong Yi
- 3 Xiong Yi
- 4 Biesse
- 5 Biesse

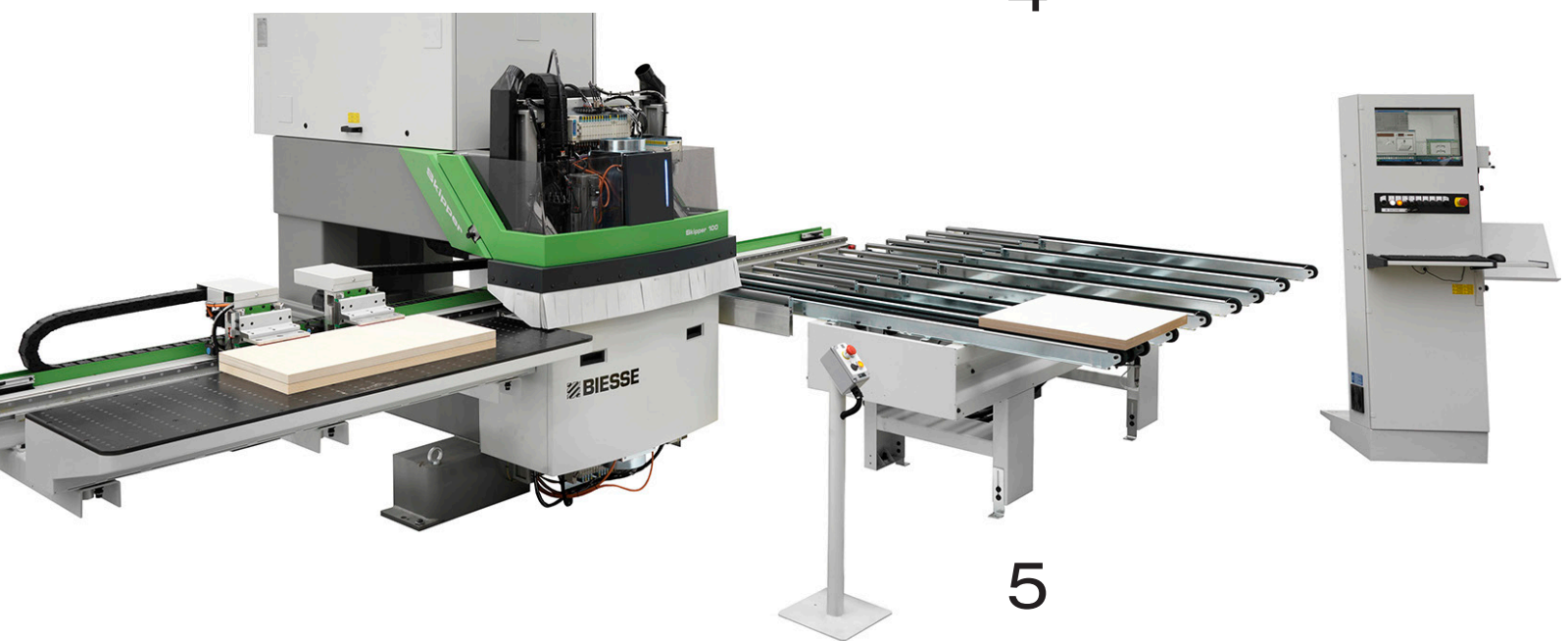

5

Products preview



1

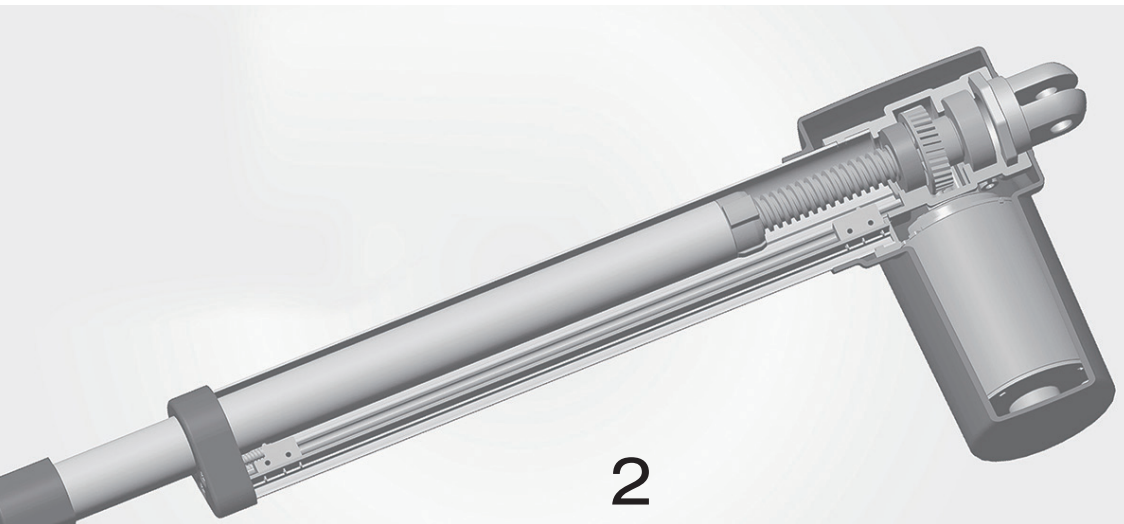

2

- 1 Anderson Group
- 2 PMT
- 3 Sinowolf Plastic Dekor
- 4 Sinowolf Plastic Dekor



3

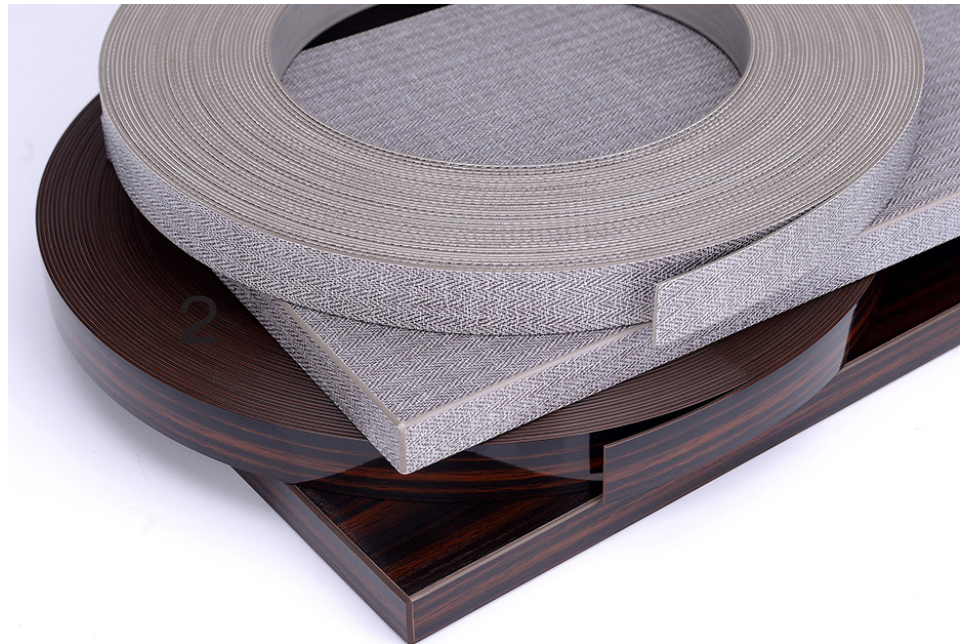

4

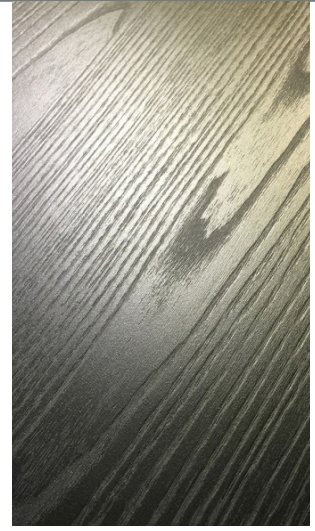

5

5
WHM
6
OPK
7
Anderson Group

6



7

Products preview



1



2

- 1 Sandar
- 2 Tongan
- 3 Sandar



3



- 4 Homag
- 5 Tongan
- 6 Homag

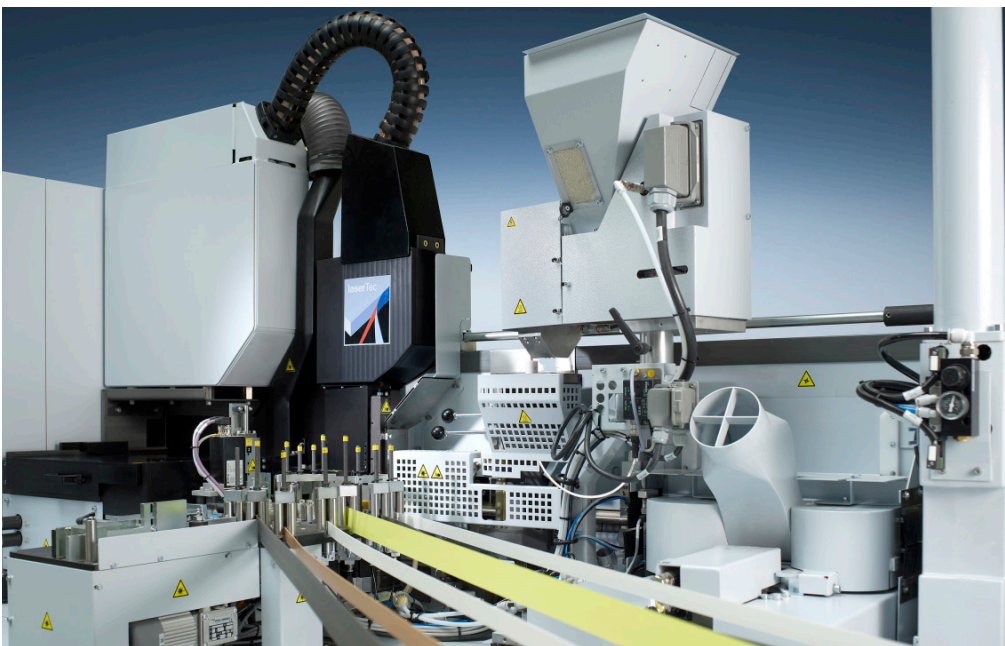

Tasting Zen in Tea

What is the beauty of oriental aesthetics in a Chinese tea house?



The Beauty of Lotus over Clear Water

In a number of different home furnishing projects, neo-Chinese design carries forward the quintessence

of traditional Chinese style and oriental aesthetics so as to amaze people with its artistic conception.



The Beauty of a Mosaic of Colors and Ornaments

Mr. Zong Baihua, a modern Chinese aesthetician, has pointed out that Chinese aesthetic types can be divided into “a mosaic of colors and ornaments” and “lotuses over clear water”. These two types of beauty have their unique charm and, in the history of Chinese aesthetics, are considered to represent two different

kinds of aesthetics, or beautiful ideals. For the beauty of “Lotuses over Clear Water”, the tea ceremony and floriculture elements are the most striking. “People cannot live without tea in a day.” Let’s savor the oriental charm in a Chinese tea house.



Regardless of whether the context is one of mansions, buildings or small rooms, their design should be

exquisite, elegant and considerate. The furnishings should reflect elegance and fun.





A tea house calls for tranquility and elegance instead of extravagance, it gives importance to the overall rationality of space, and focuses on primitive simplicity,

elegance and tranquility.
More empty spaces, no fancy decoration.



The Real Reasons for Unwillingness to Work? You May Not Believe It...

"I always feel that I'm not suitable for work and only suitable for getting paid because of my character"... "There are always 20 or 30 days in a month when I don't want to work"... "Put off today what you can do tomorrow. This is

the most basic respect for life". Only "Ge You slouch" (Chinese slang to say be a lazybones) instead of the "nine to five" has become a psychological normal of office workers. Behind this phenomenon, a hidden important

reason cannot be ignored, that is: there is a lack of desire to work in the office! The secret of the world-class office is revealed. Overtime work is an enjoyment in such a good environment. You don't believe it? Take a look!

Google

Google has always been imitated by many technology companies. Its offices across the world have their unique atmosphere and emotional design.

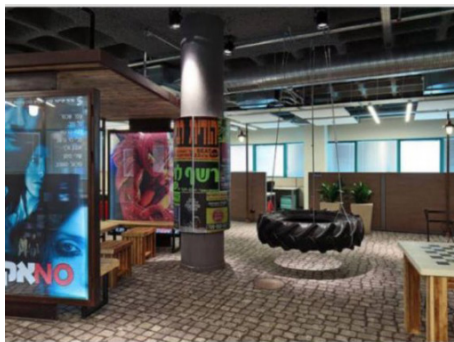

YouTube

The headquarters building of YouTube under Google is located in San Bruno. In addition to basic recreational facilities such as mini golf greens and red big slides, it is the only office under Google with full-size swimming pool. It is reported that the indoor swimming

pool is connected with the fitness center so that employees can go to the fitness center to learn how to swim and then practice in the swimming pool. The design for YouTube's headquarters building attaches great importance to the health of employees. There

are many "sports workstations" where employees can walk on the treadmill while working. Besides, the employees can bring their pets to work. I want to ask: Are you sure it is a workplace?

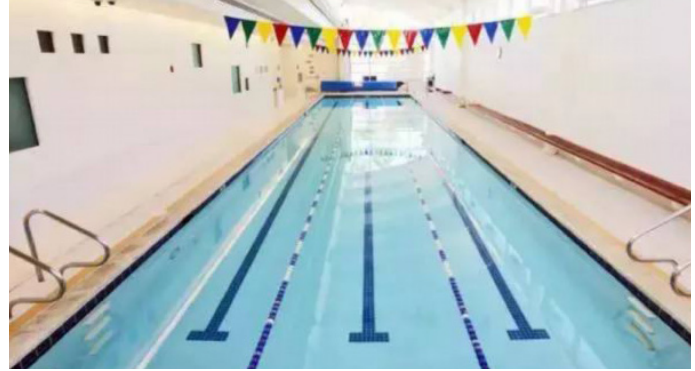

Facebook Facebook New Park

With an area of 40,000 m² Facebook New Park Office Project has the world's largest open office area. 2,800 employees work in one office. The entire office is divided into five areas with openings made so that you can walk along the corridor to

the end. It is a fantastic scene. The biggest feature of the interior design is the primary colors of logs. You can see the signs made of log everywhere. Many of them retain the original pattern of timber. The roof garden has an area of 3.5 hectares.

The half-mile undulated long walk is completed by 15 local artists. You can see beautiful sea views from the roof garden. Enjoy sea breeze, bask in the sun and have a nap after work. It's a wonderful life!



Apple Campus 2

We may say that Apple Campus 2 is Steve Jobs' last masterpiece. His concept for Apple Campus 2 is: round building, hollow and cylindrical, outer walls made of curved glass, displaying the curvature well. Trees are planted in the courtyard. The roof is covered with solar panel... Apple Campus

2 is towards Steve's idea to be realized step by step. Some people disclosed its internal design details. The toilet button is like Apple's Home key. The 360-degree viewing angle of the theater will be a stage for Apple to launch new products. How creative! The top of Apple

Campus 2 is equipped with a 700,000-square-foot new solar energy generator and a built-in natural gas distribution system, warm in winter and cool in summer. Save a lot of electricity, right?



Inventionland Design Factory

This is the office environment of the Inventionland Design Factory and an office theme park built by their designers. There are pirate ships, artificial caves, huge robots,

towers, castles in the office, surrounded by waterfalls, trees, butterflies, chirping and water sounds. It is simply the dream islands of adventure and the upgraded edi-

tion of Peach Garden. Working in such an environment is simply déjà vu of a vacation.



Microsoft House

Microsoft's new headquarters in Italy is located in Milan, and its completion ceremony was held days ago. The building is designed by architect Herzog & De Meuron.

Mr. Carlo Purassanta, general manager of Microsoft Italy explained at LinkedIn: "This building makes full use of two elements: linearity and transparency and is fully com-

pliant with Microsoft's vision." Look at the picture directly!

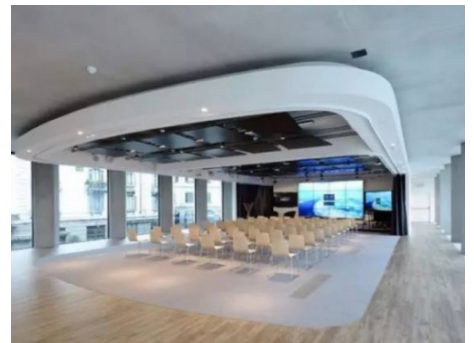



Shanghai, the city where everything is possible!

The atmosphere of freedom, of endless possibilities, together with its frenetic dynamism, make this metropolis unique; visitors will find it hard to forget! Always looking to the future, its name means “above the sea”: although the city centre is approximately 80 km from the coast, Shanghai actually faces out onto the East Chinese Sea.

Tradition and modernity blend together here in an equilibrium formed by contradictions.

To complete the day and return with your suitcase full of emotions, in addition to exploiting business opportunities you can also visit the city have the experience of a lifetime!

Shanghai is an enormous metropolis, with a population of approximately 25 million people, and spread out over a surface area of approximately 6,300 square kilometers. It is divided into 2 large areas: Puxi to the east of the Huangpu River, and Pudong to the west.

Where to go

PUXI

Puxi is the oldest part of Shanghai, and is a wonderful combination of traditional and cultural Chinese elements with 20th-century European influences.







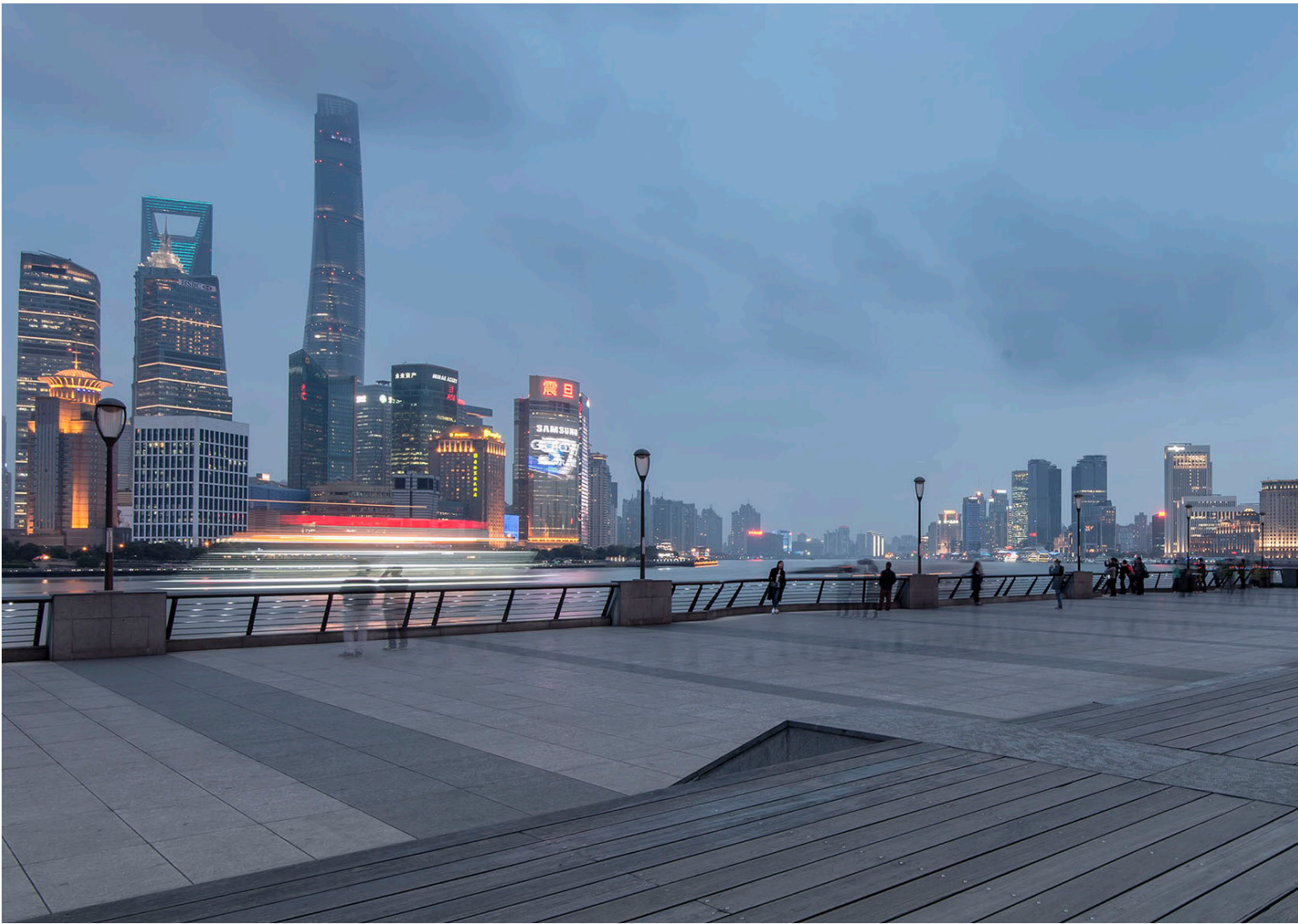

The Bund

The Bund, which is the district lying along the Huangpu River, from the Puxi side looking onto the spectacular Pudong skyline. In perfect contrast with the ultra-modern skyscrapers on the other bank of the river, here you can admire most of the art deco and neo-classical buildings, at one time considered the Wall Street of Shanghai, and which recount the last 100 years of the city. A sunset walk is something not-to-be-missed, without forgetting that the most attractive and glamorous bars and restaurants in Shanghai are located right inside these wonderful buildings.

Nanjing Road

Very long, approximately 6 km, of which just more than 1 km is pedestrian precinct, it cuts the Puxi area perfectly into two parts. Hypnotic, with its thousands of neon signs, always swarming with people, here you can really find anything and everything; shopping malls, restaurants, world famous brands, traditional Shanghai stylists and Chinese street food.





Jing'an Temple

The original temple was built in 1216 during the Song Dynasty; converted into a plastic factory and emptied of all its statues during the Cultural revolution, it has now been completely restored and stands out in surprising contrast with the modern architecture of West Nanjing Road; golden and shining, truly an enchanting sight in the evening. Inside, important statues like the 15 ton silver Big Buddha, almost 9 metres tall, and the 5 ton statue of Guanyin carved from a thousand-year-old camphor tree.



French Concession

Typified by low buildings, here you can breathe in the atmosphere of old Shanghai. It is a very extensive area, with many tree-lined avenues, lovely colonial villas, small shops, elegant galleries but also restaurants and cafes. A must-do activity is a walk to **Xin Tian Di**, an example of urban reconstruction, testament to the traditional mud brick buildings. The 1st National Congress of the PCC was held here and it is now a pedestrian area where you can stroll around, listen to music, drink, eat and go shopping in the wonderful shops, which are some of the most expensive in the city.

Similar to Xin Tian Di, more closely linked to local traditions and less artificial, **Tianzifang** is a district that is distinctive for its extremely narrow lanes and 1930s buildings, a place where you can stroll around or have something to eat in one of the many elegant small restaurants.

Yuyuan Gardens & Bazaar

These “Gardens of Happiness”, dating back to the second half of the 16th century, were created in 18 years by the Pan family, which belonged to the Ming Dynasty. They consist of reflecting pools of water and streams, large rocks, dragon-decorated walls, gates and zigzag bridges to confuse the spirits. Beside the gardens lies Yuyuan Old Street, an ancient and extremely well-conserved lane, lined with more than 200 silk, tea and jade shops. Nearby is God’s Temple, a Taoist temple dedicated to the City God.

Jade Buddha Temple

This Buddhist monastery built at the beginning of the last century is an example of typical Song Dynasty architecture. It is approximately 2 metres in height, and is carved from a block of white jade decorated with precious stones.





PUDONG

True symbol of Chinese dynamism and economic development, farmland until 1990, and now the most modern heart and soul of the city, and also its commercial and financial centre. All the tallest skyscrapers are packed together here, including the iconic three-legged **Oriental Pearl TV Tower**, symbol of the city. The futuristic-style tower, 468 metres high, has various observation levels. The lowest is at 263 metres, while the highest is at 351 metres. Inside the tower there is a revolving restaurant, at 267 metres, an exhibition area, a small shopping centre and the Shanghai History Museum.

With its oriental design influenced by the Western Gothic style, at 421 metres tall, **Jin Mao Tower**, was for years the tallest building in China, equipped with a no-stop elevator from ground level to the 88th floor, where there is a magnificent “belvedere” viewpoint. The spatial scansion of the entire building is based on the number 8, a traditionally lucky number for the Chinese.







The Shanghai World Financial Center, better known as “**the corkscrew**”, because of its shape, is 492 metres and 101 floors high; breathtaking views can be had from the **Sky Walk** observatory on the hundredth floor; at one time the tallest building in the city, it has now been surpassed by the **Shanghai Tower**, 128 floors and 632 metres taller. Opened around one year ago, this tower is spiral-shaped in order to reduce the wind stress; it is the second tallest skyscraper and one of the most eco-sustainable buildings in the world. From the **Top of Shanghai Observatory**, on the 118th floor of the tower, you can enjoy a breathtaking 360 degree view of Shanghai. The world’s fastest elevator will take you up to 546 metres in just 55 seconds, from the **Top of Shanghai Exhibition Hall** on floor B1, where there are multimedia displays telling you about the history and features of the Shanghai Tower.





匠心质造
全能对接
Better Life
Better Work

BETTER LIFE BETTER WORK CHINA GUANGZHOU/SHANGHAI INTERNATIONAL FURNITURE FAIR



March in Guangzhou · Pazhou



www.ciff.furniture



September in Shanghai · Hongqiao



The 41st China International Furniture Fair (Guangzhou)

18-21 March 2018

[home/homedecor/hometextile/outdoor](#)

28-31 March 2018

[office/hotel/commercial/materials&machines](#)

China Import and Export Fair Complex & PWTC Expo



The 40th China International Furniture Fair (Shanghai)

11-14 September 2017

[home/homedecor/hometextile/outdoor](#)
[office/hotel/commercial/materials&machines](#)

National Exhibition and Convention Center (Shanghai) in Hongqiao

